

FLOORPLAN/PLANO. Ref. 2102
403m2 Build size/construida
298m2 usable/util

1st floor/ Planta primera 58m2

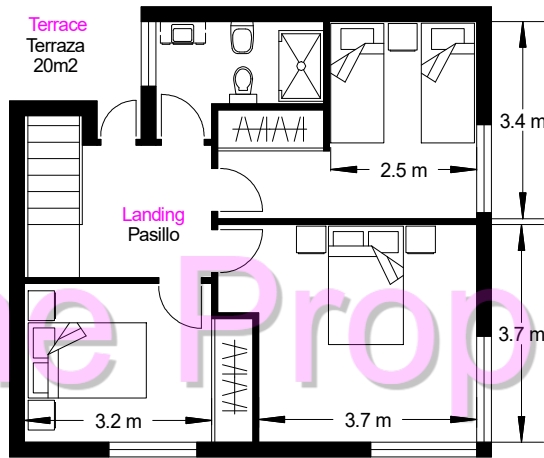

Detached Garage/ Garaje 53m2

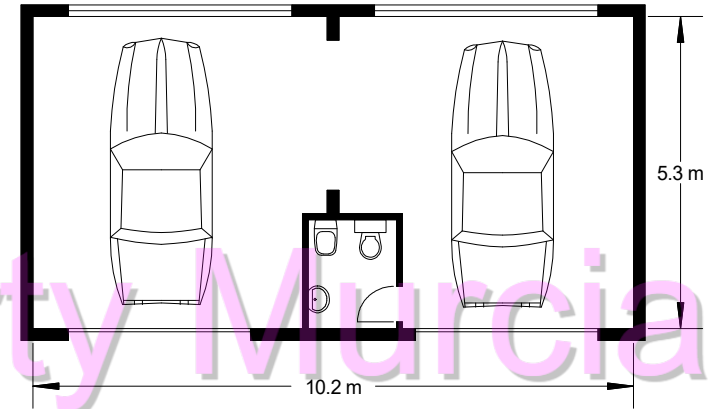

Ground floor/ Planta baja 146m2

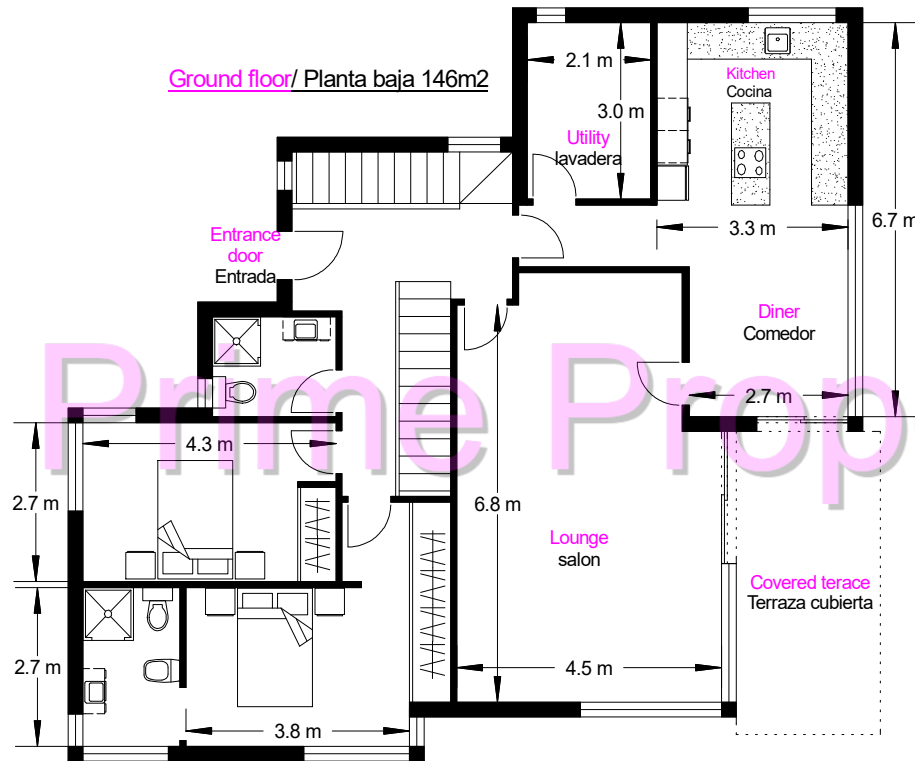

Basement/ Sotano 145m2

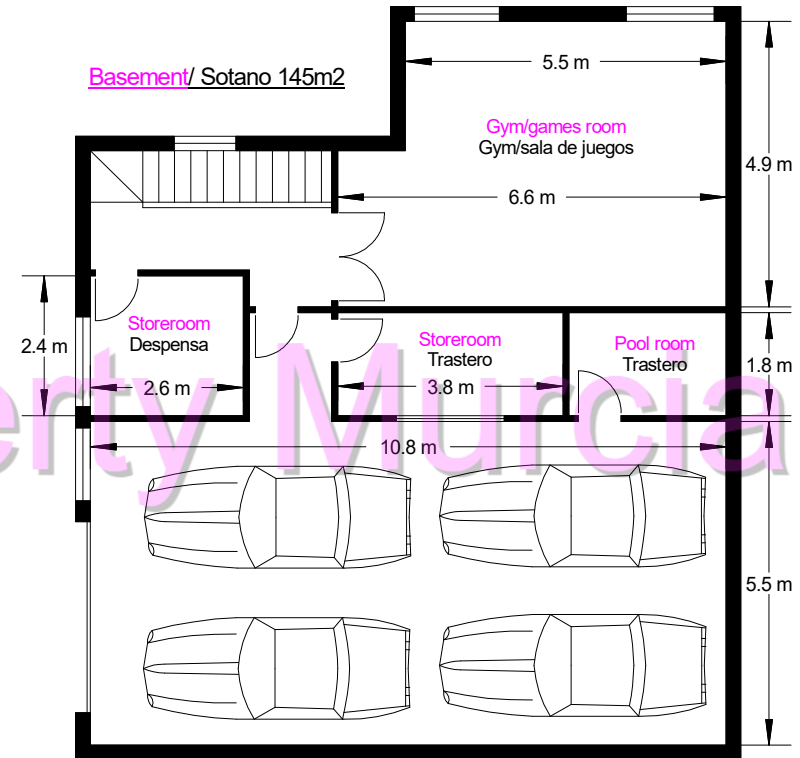

N.B.
 All plans, distribution, furniture and dimensions are for guidance only and should not be used for any other reason. Personal viewings are always recommended when purchasing a property.
 Todos los planos, distribución, mobiliario y dimensiones son sólo orientativos y no deben utilizarse por ningún otro motivo. Siempre se recomiendan visitas personales al comprar una propiedad.